

# COMPARING METHODS TO DETERMINE THE HEALTH OF BATTERY SYSTEMS

by  
John O'Connor, Thomas Leonard, Gene Bohensky  
BTECH, Inc. 10 Astro Place, Rockaway, NJ 07866

## ABSTRACT

There have been many papers written about methods used to determine the health of batteries in critical standby applications. This paper intends to produce a critical analysis of the various AC "impedance" and DC "resistance" or "voltage response" measurement methods used in both portable (off-line) battery testing equipment and stationary (on-line) battery monitoring systems commonly found today. What is most important to users is having proper runtime during a loss of power, and any test or monitoring equipment must accurately pick out failing cells before this runtime value is unacceptable. The ability to determine the health of the battery properly is affected by the method of monitoring used, and a close-to-ideal method based on pulsed DC impedance is presented along with case studies to illustrate.

## INTRODUCTION

Stationary battery monitoring systems and portable battery testers based on "ohmic" testing have become more common through the 1990s and early 2000s, with many technologies used still under patent protection. Impedance methods use a controlled Alternating Current test load signal, either a sinusoidal or square wave (sometimes referred to as pulsed DC type), and measure the AC voltage to calculate impedance *while the test load is applied*, while Resistance methods use a longer DC load signal to determine the "internal resistance" of the battery by measuring the voltage response of the battery *after the test load is released*.

## HISTORY: FINDING METHODS TO DETERMINE THE HEALTH OF BATTERY SYSTEMS

In the late 1970s efforts were underway to develop methods to "find" failing cells in a string of batteries in advance with enough time to take action before the integrity of the backup system was affected. Until this point, the only way to truly determine the health of standby batteries was to perform an invasive and costly discharge test. What if a simple way could be found to find failing cells without this test, and while the battery system was on line?

## THE DISCOVERY OF IMPEDANCE AND INTERNAL RESISTANCE ("VOLTAGE RESPONSE") METHODS

Much research has been done to determine common battery failure modes. By measuring profiles of a battery when new and comparing these parameters over time, one can predict failures of individual batteries in the string, thus protecting the entire string. The parameter that was determined to have the most promise was the internal impedance of the battery (the resistive portion of the battery as influenced by the battery's capacitance or ability of the battery to store energy) measured at a frequency unaffected by AC ripple or electrical noise. Detecting impedance rise over time can indicate common impending failure in sealed (VRLA) lead acid batteries due to post, grid and strap-to-grid corrosion, plate cracking and/or warping, and cell dry-out. Loose or corroded battery bus connections are also detectable via the rise in impedance. For Wet (Flooded) Cell batteries impedance rise also corresponds with similar, although less common internal failures. The ideal properties monitoring or testing systems using impedance would be:

- 1) Data should be provided with the highest degree of accuracy and consistency, so that trends may be identified as soon as possible, providing the most time for the user to take corrective action.

2) Testing should be non-invasive and should not place a deep discharge (below open-circuit voltage) on the batteries during the measurement cycle. This makes sure the life of the batteries is not affected by repeated testing.

### PULSED DC IMPEDANCE

During the late 1980s a method of trending battery impedance over time - based on individual unit baselines and without going below the open cell voltage - was developed, patented and deployed over thousands of battery systems. :

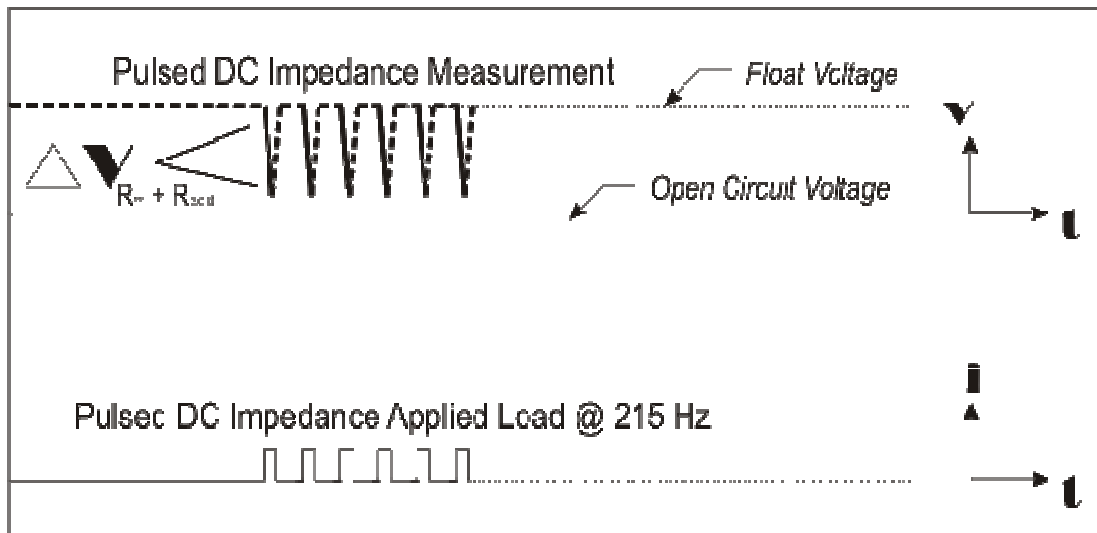

**FIGURE 3 – PULSED DC IMPEDANCE METHOD**

The system's method of operation is shown in Figure 3, above. A test AC load is applied in a pulsed DC form on a lead acid battery with the resultant voltage response, with the lower waveform representing the applied load vs. time and the upper waveform the resultant voltage response, as measured across the positive and negative terminal. The method used to create the measurement frequency is actually pulsating DC and is analyzed as a time varying current with a DC offset. This is different from an AC waveform that both charges and discharges the cell, creating a condition where the charge is alternately put in and taken out of the cell. This waveform produces a true mini load on the cell with a very small total energy value.

With this method, an approximately 2 second test load is placed on the battery at 215 Hz, between 2.5 and 10 amps RMS depending on the battery type. This range of test amperages was chosen to ensure that the testing would never bring the battery below open cell voltage, and the frequency was chosen to stay away from any harmonic of 50 and 60 cycle ripple that may be present on the battery string. It would be a problem to measure at 50 or 60 hertz or any multiples thereof as measurements would not be consistent enough for trending. Additionally, modern filters and firmware techniques are used to eliminate any residual effects of these and other frequencies on the measurements.

The impedance is calculated via Ohm's law from the voltage response at the test frequency and the test current *while the load is being applied*. This method meets all of the ideal criteria, as the battery does not need to be discharged below open circuit voltage and the measurement can be made while the system is on-line. This method most accurately obtains the  $R_m$  and the  $R_{acid}$  values that correspond with battery health. Other papers have stated that such measurements are

adversely affected by the frequency at which the measurement is made, based on plugging numbers in the visual “Randles” battery model. Although the measurement frequency can affect the data, in reality this effect is minimal at less than 1000 Hz. This is proven by analyzing actual real-world measurement data, which is demonstrated later in the paper. More important is the ability to detect a trend early, and it is here that the impedance method excels.

### CASE STUDY #1 – Typical Impedance Failure for 12V VRLAs

In Figure 4 a typical impedance rise signature for a failing 12V battery at an actual customer site is shown for our first case study. This customer in Northeast United States experienced a full battery discharge during the blackout of August, 2003. The rise in impedance started just a few weeks after the discharge event, a common occurrence. One should note that a discharge event like this one could also be a load bank test to determine battery runtime, a common practice. Some points to illustrate:

- 1) Each yellow point represents one week of time between measurements.
- 2) The green line represents the initial baseline measurement *for the actual battery* which is measured and stored in the system when the battery is first installed. This is important, because this initial baseline can vary up to 20% from factory or average baseline values most often used as general baselines for all cells in most commercial monitoring systems.
- 3) The red line is the maintenance alarm at 20% rise; the purple is the critical alarm is set at 30%.
- 4) In review of hundreds of battery failures, it has been determined that the time between reaching the 30% rise and outright failure is unpredictable and can be as short as two weeks.
- 5) The Voltage measurements remained within normal operating limits during this time.
- 6) Notice the consistency of the repeated measurements over time - this is a hallmark of the impedance method, even on noisy battery systems.

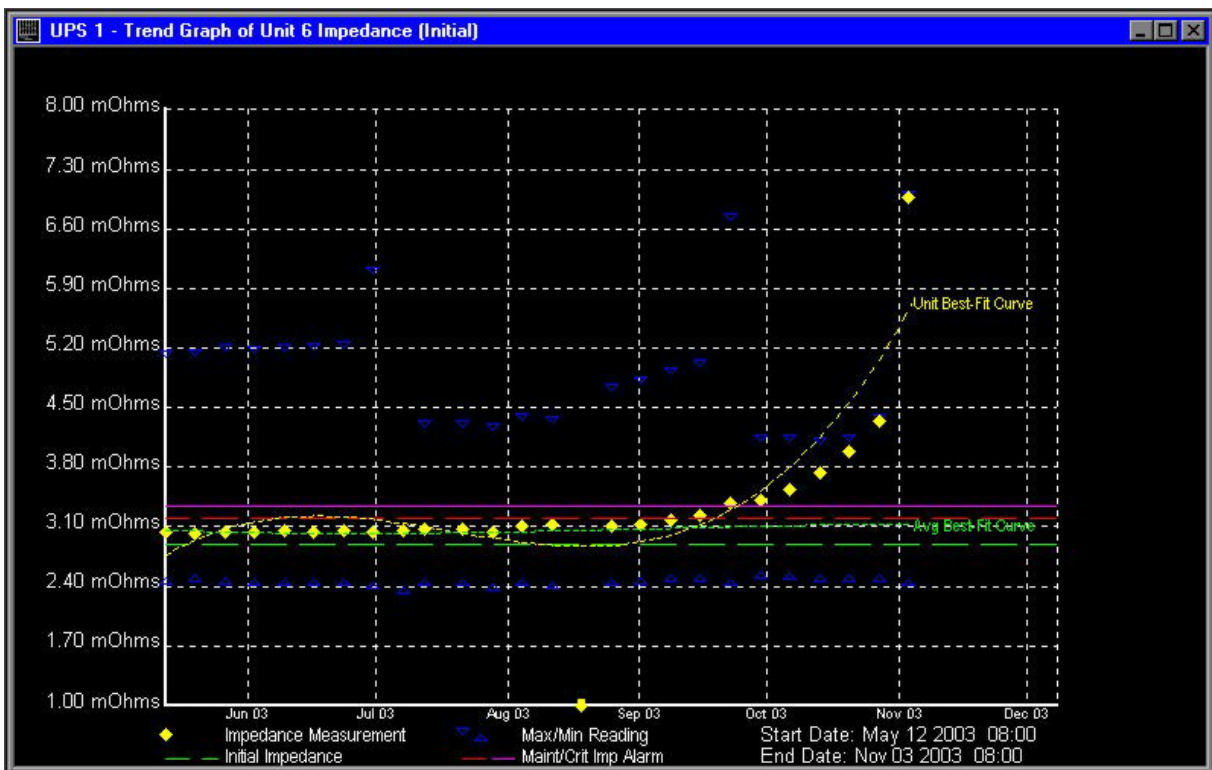

FIGURE 4 – TYPICAL IMPEDANCE RISE FOR A FAILING 12V VRLA BATTERY OVER TIME

Being able to detect the internal impedance rise of a battery in advance of failure allows the manager of the battery system to take action before there is a risk to the critical power system.

### CASE STUDY #2 – IMPEDANCE vs. BATTERY PERFORMANCE UNDER LOAD

The second case study comes from a customer who installed a Pulsed DC battery monitoring system on a stack of 60 2V large VRLA on a switchgear application. The impedance values for these batteries are shown in Figure 5, with the five highest values highlighted with red triangles.

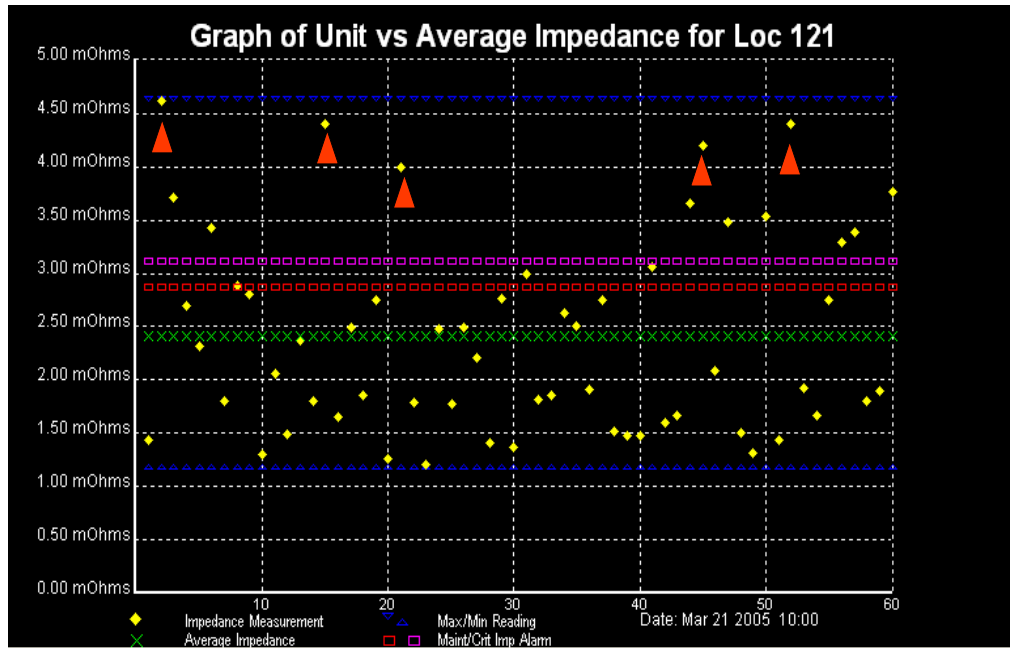
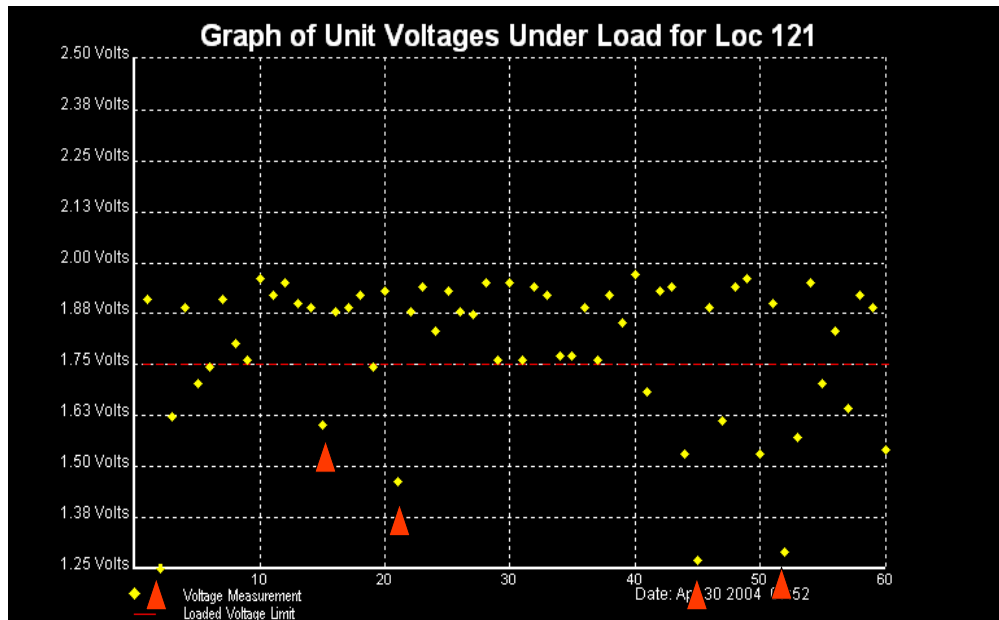

FIGURE 5 – IMPEDANCE VALUES ON 60 - 2V LARGE VRLA BATTERIES

A light 20A discharge was placed on this battery system for two hours. After this time, the unit voltage measurements were taken from the system. The cells with the lowest end voltages neatly corresponded with their high impedance measurements before the test, demonstrating that high impedances correlate well with declining state of battery health.



**FIGURE 6 – VOLTAGE VALUES ON 60 - 2V LARGE VRLA BATTERIES AFTER 2Hr. LOAD TEST VOLTAGE RESPONSE (“Internal Resistance”)**

Voltage Response or “Resistance” testing is illustrated in the graph below. This method proves to be effective while the batteries are disconnected from the critical load. On-line testing reduces the effectiveness of such a system in real world applications due to charger influence and noise.

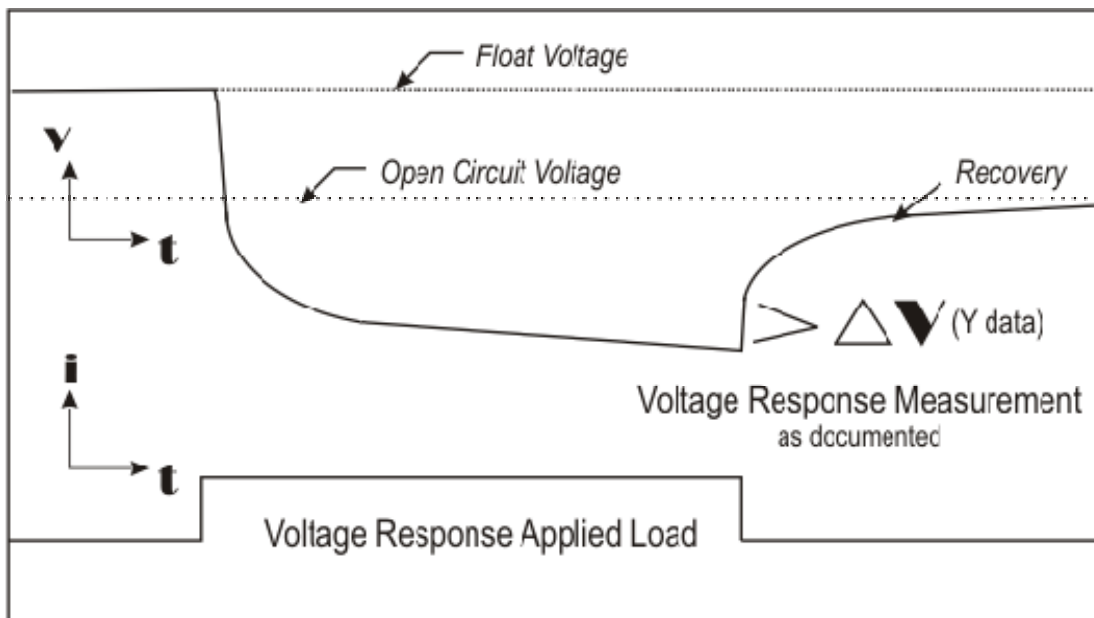

**FIGURE 7 – VOLTAGE RESPONSE (“RESISTANCE”) METHOD AS DOCUMENTED**

This method uses an approximately 3 second duration test load of between 30 and 70 amps is placed on the battery that may bring the voltage below open circuit level, as shown in the graph. Figure 7 illustrates the application of this DC load on a lead acid battery with the resultant voltage response, with the lower waveform represents the applied DC load vs. time and the upper

waveform the resultant voltage response, as measured across the battery terminals. This measurement method attempts to capture the fast recovery step (Y Data) of the voltage curve *after the test load is released*. In many applications, the battery is discharged below the open circuit voltage, as determined by how the battery responds to the 30-70 Amp load over the 3 second test. The initial voltage response step is relatively instantaneous and it is this voltage jump that is used to calculate the resistance, representing the value of  $R_m$  and the  $R_{acid}$  values. During the time the applied load is removed, three things happen simultaneously:

- 1) The voltage across  $R_m$  and  $R_{acid}$  instantly rebound;
- 2) The exponential recovery of the voltage, including the effects of the charger current and the diffusion of acid into the boundary layer representing the discharge of the capacitor;
- 3) Ripple or noise present within the system impacting the measurement.

For hand-held test equipment, this method has proven useful because while the battery is off-line, the inherent ripple or noise present in on-line systems is not there to affect measurements. The objective of the resistance measurement is to solely measure the  $R_m$  and  $R_{acid}$ , yet the simultaneous occurrence of recharge current, ripple noise and sampling time all impact on the accuracy of the voltage recovery (Y Data measurement) and thus the resistance measurements.

### ANALYZING THE VOLTAGE RESPONSE METHOD; COMPARISON TO PULSED DC IMPEDANCE

In order to determine whether these theoretical issues would affect real-world measurements, readings from portable devices based on pulsed DC impedance and voltage response following an applied discharge current of 100 amps were tested on identical batteries. For the voltage response method, the data sampling time (sampling frequency) is critical to the "Y Data" value measured, because unless the sampling time is short enough, the data value will contain a combination of all of these events, not all of them representing the actual "resistance". Figure 8 shows the voltage response of the three different battery types tested.

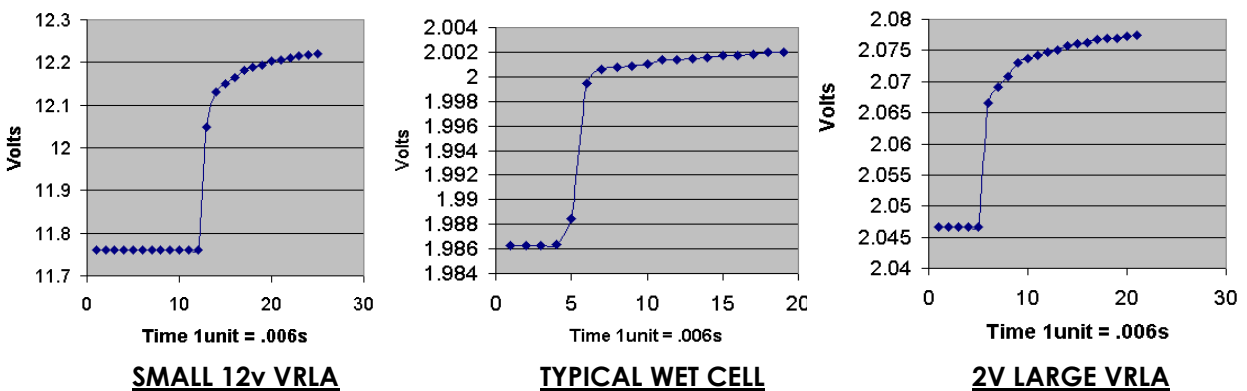

FIGURE 8 – VOLTAGE RESPONSE CURVES FOR POPULAR BATTERY TYPES

In order to deduce the ability of the voltage response equipment to make accurate measurements, readings for three popular battery types were made with a portable impedance tester and a portable resistance tester. Results for voltage response ("resistance") were compared with hypothetical calculations made with the measured response characteristics shown in the graphs above, using *only the voltage recovery portion of the response curve*. The average results over multiple readings are shown below in Figure 9. Some points:

1. The Pulsed DC Impedance method at 215 Hz produced results very close to the hypothetical voltage response method using only the instantaneous (linear) voltage response portion of the recovery.
2. The actual values produced by the Voltage Response equipment were in some cases up to 50% higher than the hypothetical, and in others similar. Looking at the actual graphs, it was deduced that the Voltage Response equipment had a sampling time of 0.016 ms, or approx. 3 time points on the curves shown above. It would appear that this 0.016 second interval was chosen to limit the effects of 60 Hz ripple on the measurement (0.167 seconds being the time duration of one complete 60Hz cycle).
3. The readings by the Voltage Response equipment for batteries on-line varied by up to 10% for each measurement, while the impedance equipment showed minimal variation of 1-2%.

<u>Battery</u>	<u>Impedance Method - Actual</u>	<u>Voltage Response Hypothetical</u>	<u>Voltage Response Actual Readings</u>
	Small UPS VRLA	3.3	3.7
Typical Wet Cell	0.15	0.14	0.14-0.16
2V Large VRLA	0.19	0.19	0.27-0.30

**FIGURE 9 – COMPARISON OF READINGS (in mohms)**

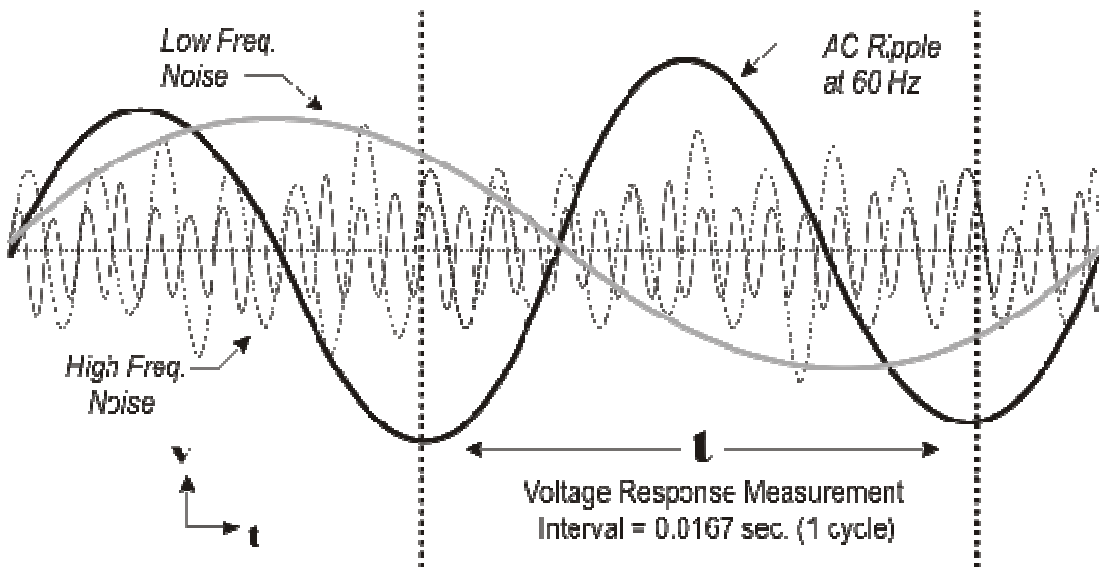

**FIGURE 10 – TRUE VOLTAGE RESPONSE (“RESISTANCE”) METHOD AND NOISE**

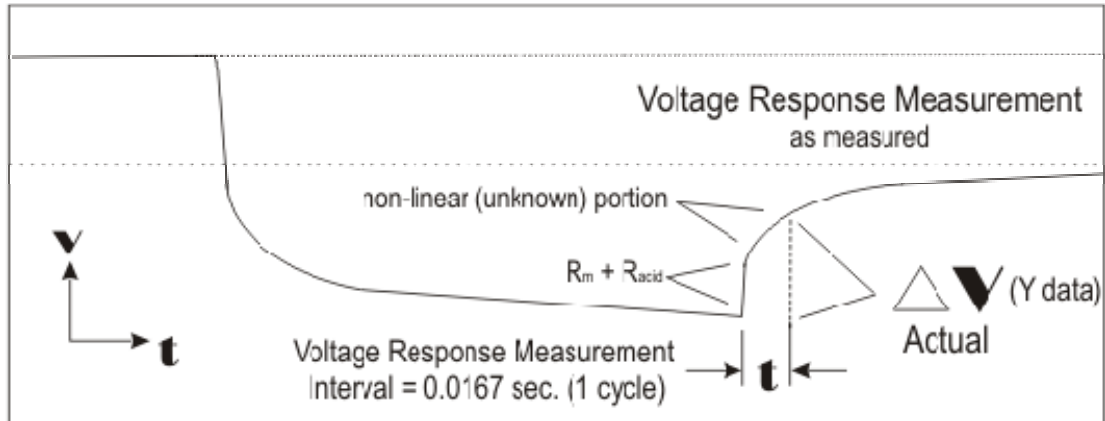

**FIGURE 11 – TRUE VOLTAGE RESPONSE (“RESISTANCE”) METHOD AS MEASURED**

### **LIMITATIONS OF VOLTAGE RESPONSE METHOD AND NOISE ALIASING FOR ON-LINE SYSTEMS**

As we measured in the previous section, the time span of the voltage response measurement chosen for on-line battery systems is roughly 0.0167s or the time of one complete 60Hz cycle. This span was obviously chosen to cancel the effects of 60Hz ripple current and its associated harmonics on the measurement result. In this fashion it can be accurately stated that this method is not affected by standard AC ripple, but this is misleading. There are two significant drawbacks to using this method:

- 1) The voltage response method, when used on on-line battery systems, includes all net effects of any noise present during the 0.0167s measurement cycle. It is true that any straight ripple noise at 60 or any harmonics thereof are cancelled out; however such noise is present virtually throughout a spectrum of 20-30 kHz. In the real world, it becomes apparent that this method cannot give the consistent and reliable results that one can obtain with a pulsed DC impedance measurement signal. See figure 10 for a visual representation.
- 2) Using the voltage response method with a 0.0167 second measurement time includes both the instantaneous voltage response and a portion of the non linear (and non-resistive) portion of the recharge curve. This recharge curve is partially affected by the charger and is not related to inter-cell resistance. This explains why readings can be up to 50% from typical impedance readings, which do not include this effect. See Figure 11 for a visual description.

### **CONCLUSION: THE IDEAL BATTERY TESTING & MONITORING METHOD**

Methods have been described that demonstrate the ability of systems to provide data on a theoretical basis in many white papers. Some have even demonstrated measurement data obtained from a simulated laboratory test. Experience has shown that the largest obstacle to overcome, independent of the measurement method, is getting the systems to provide reliable and consistent data in a real-world application. When doing testing on systems that are on-line, the presence of different electrical interference noise and ripple current patterns over the battery system (whether generated from the UPS, load or the environment) present a challenge that is effectively new with each installation. Many approaches that work in an environment free of electrical noise - such as when the battery is removed from the string for testing - simply will not provide stable data in applications that subject the battery to noise not only from the charger (rectifier) but from the load. This is a very important concept, because these methods will produce inconsistent and in many cases misleading data when testing individual batteries in on-line applications.



As documented in this paper, the Pulsed DC impedance method has been clearly demonstrated to provide the most accurate and consistent measurements possible, whether used in a portable measurement device or a stationary on-line monitoring system, because of its ability to get reliable and consistent trend data.

References:

- Modeling and evaluation of valve-regulated lead-acid batteries by Ander Tenno. Helsinki University of Technology Control Engineering Laboratory 2004.
- Electrochemical Impedance Spectroscopy Theory: A Primer. Gamry Instruments 2005.
- Ohmic Measurements, The History and the Facts, Glenn Alber, 2003
- Predicting Battery Performance Using Internal Cell Resistance, Glenn Alber, 1998
- Impedance Monitoring...An Added Dimension, G.J. Markle, 1995
- Battery Failure Prediction, Manfred R. Laidig and Jack Wurst, 1992